



# DOUBLE NESTING BOX

Item # GNB2

## Component Parts:

### Contents:

- 1. Top panel (1)
- 2. Right side end panel (1)
- 3. Left side end panel (1)
- 4. Center division panel (1)
- 5. Front cross brace (1)
- 6. Rear cross brace (1)
- 7. Plastic nesting box (2)
- 8. Nesting box cover (2)

### Hardware Package:

- Bolt- M5 x 8mm (12)
- Nut- M5 (12)
- L-Shaped screw (2)
- Nylon screw anchor (2)

### Tools Needed:

- Flat-head screwdriver
- 8mm wrench

## Assembly & Installation Instructions:

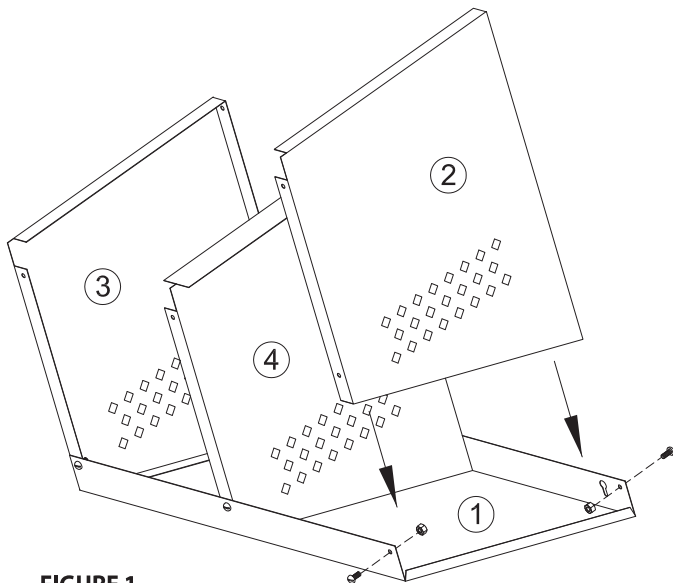

**FIGURE 1**  
Mount the right and left side end panels and two division panels as shown and screw into place

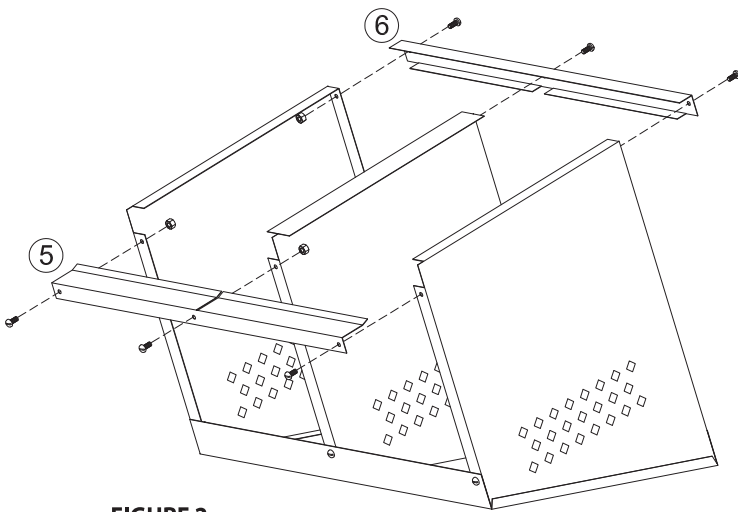

**FIGURE 2**  
Fit the front and rear cross braces to the panels as shown, and screw into place

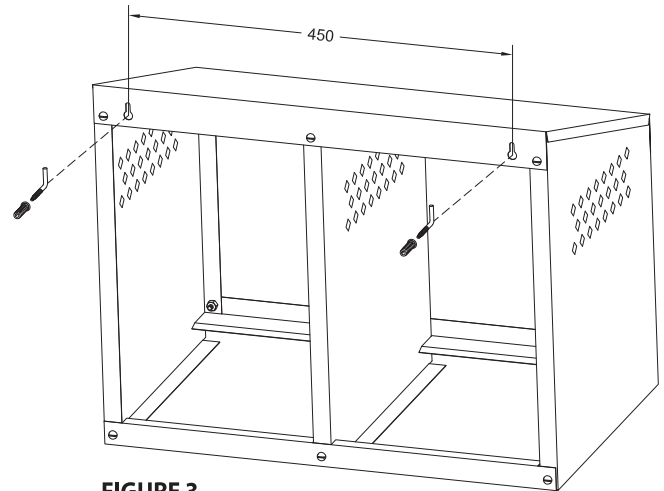

**FIGURE 3**  
Mark the holes on the mounting surface using the nesting box as a template

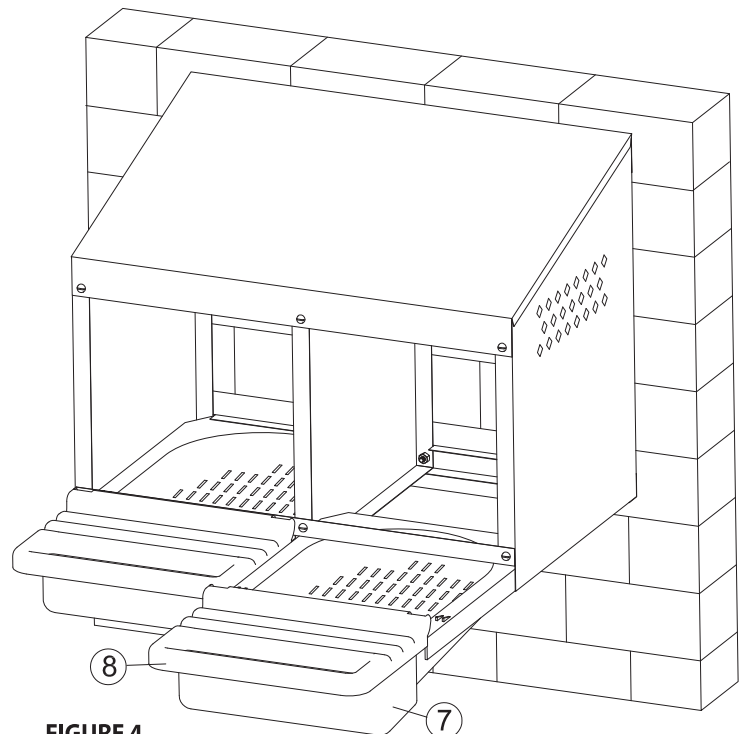

**FIGURE 4**  
Hang the plastic nesting boxes and install the nesting box covers.



# NIDAL DOBLE

Nro. de artículo: GNB2

**Componentes:****Contenido:**

- |  |                          |
|--|--------------------------|
| 1. Panel superior (1)                    | 5. Cruceta frontal (1)   |
| 2. Panel terminal del lado derecho (1)   | 6. Cruceta posterior (1) |
| 3. Panel terminal del lado izquierdo (1) | 7. Nidal de plástico (2) |
| 4. Panel divisor central (1)             | 8. Cubierta de nidal (2) |

**Paquete de accesorios de montaje:**

- Tornillo- M5 x 8 mm (0.314 pulgadas) (12)
- Tuerca- M5 (12)
- Tornillo L (2)
- Tornillo de anclaje de nylon (2)

**Herramientas necesarias:**

- Destornillador de hoja plana
- Llave de 8 mm (0.314 pulgadas)

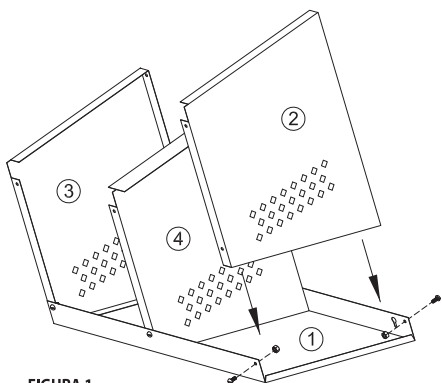
**Montaje e Instrucciones de instalación:****FIGURA 1**

Instale los paneles terminales en los lados derecho e izquierdo y los dos paneles divisores como se ilustra y atornillelos

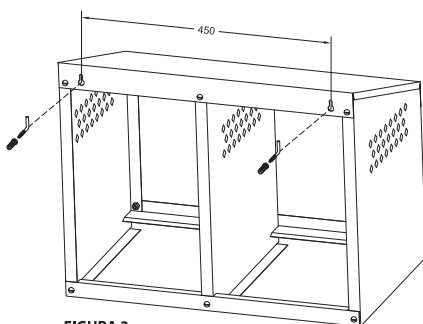
**FIGURA 3**

Marque los orificios en la superficie de montaje utilizando el nidal como plantilla

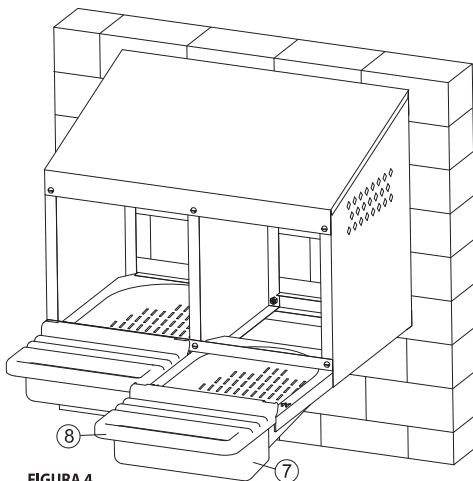
**FIGURA 4**

Cuelgue los nidales de plástico y colóquelas las cubiertas



# BOÎTE DE COUVAISON DOUBLE

Article no GNB2

**Composants :****Contenu :**

- |                                    |   |
|------------------------------------|---|
| 1. Panneau supérieur (1)           | 5. Attelle transversale avant (1)         |
| 2. Panneau d'extrémité droit (1)   | 6. Attelle transversale arrière (1)       |
| 3. Panneau d'extrémité gauche (1)  | 7. Boîte de couvaion en plastique (2)     |
| 4. Panneau de division central (1) | 8. Couverture de la boîte de couvaion (2) |

**Quincaillerie dans l'emballage :**

- Boulon - M5 x 8 mm (0,31 po) (12)
- Écrou - M5 (12)
- Vis en L (2)
- Ancrage de vis en nylon (2)

**Outils requis :**

- Tournevis à tête plate
- Clé de 8 mm (0,31 po)

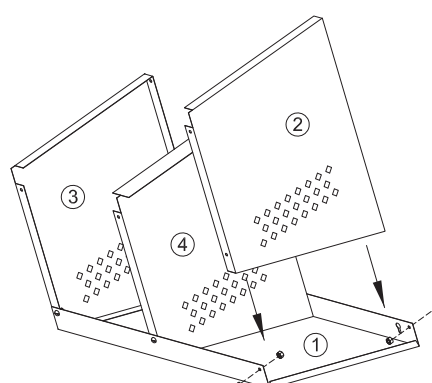
**Directives de montage et d'installation :****FIGURE 1**

Installer les panneaux d'extrémité droit et gauche et les deux panneaux de division, comme montré, et visser les vis.

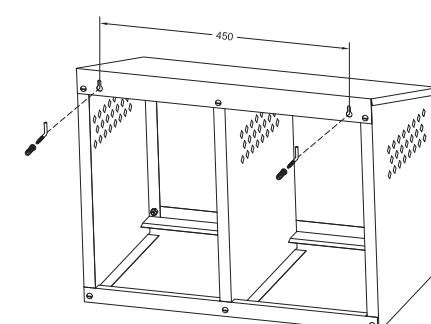
**FIGURE 3**

Marquer les trous de la surface de montage en utilisant la boîte de couvaion comme modèle.

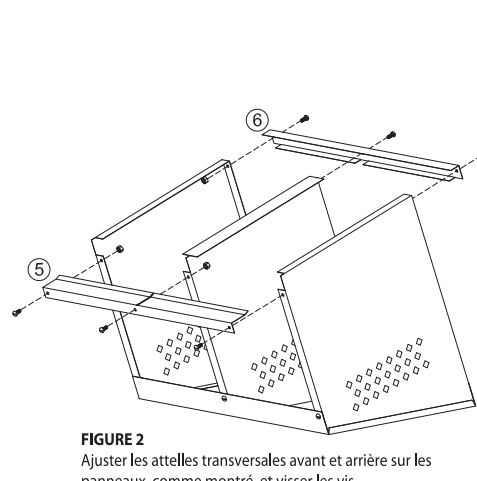
**FIGURE 2**

Ajuster les attelles transversales avant et arrière sur les panneaux, comme montré, et visser les vis.

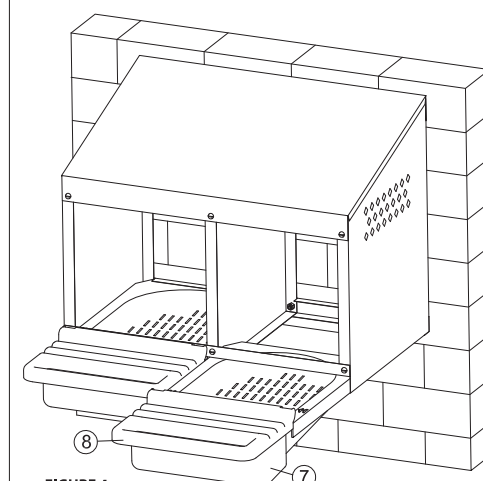
**FIGURE 4**

Suspendre les boîtes de couvaion en plastique et installer les couvercles de boîte de couvaion.