



Installation Instructions

CP8 8 Quart Calf Pail Hanger Bracket Installation

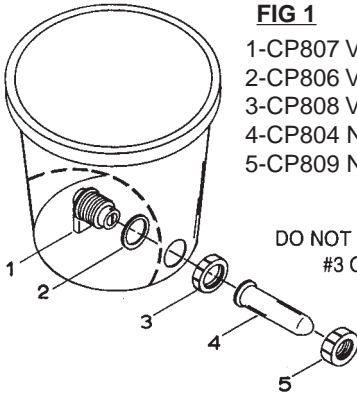

FIG 1

- 1-CP807 Valve Body
- 2-CP806 Valve Gasket
- 3-CP808 Valve Body Retainer Nut
- 4-CP804 Nipple
- 5-CP809 Nipple Retainer Nut

DO NOT OVERTIGHTEN
#3 OR #5

FIG 1 replacement parts
available to purchase:

CP805CPK-Valve Assembly
Contains #1, 2, 3, 5

CP804PK-Nipple
Contains #4

See FIG 2

- Line up top of mounting plate (2) with 8 quart graduation mark on the inside of the pail.
- While holding mounting plate in place, trace 4 holes onto bucket for drilling.
- Remove mounting plate.
- Drill 4 - 1/4" holes.
- After holes are drilled, line up the mounting plate on the inside of the bucket with the holes. Also line up the brackets on the outside of the bucket with the holes.
- Thread bolts through mounting plate, bucket and mounting brackets.

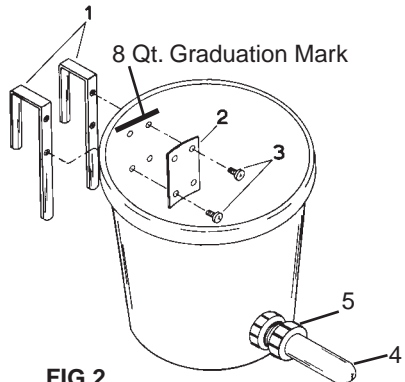

FIG 2

- 1-CP801 Hanging Brackets (2)
- 2-CP802 Mounting Plate
- 3-CP803 1/4" x 3/8" Bolts (4)
- 4-CP804 Nipple
- 5-CP805CPK Valve Assembly

FIG 2 Replacement parts
available to purchase:

CP8KIT-Parts kit
Contains #1, 2, 3, 4, 5

MILLER MANUFACTURING COMPANY

1450 West 13th Street • Glencoe, MN 55336 USA
(651) 952-5100 • FAX (651) 982-5101

www.miller-mfg.com